

# BOR CARBIDE

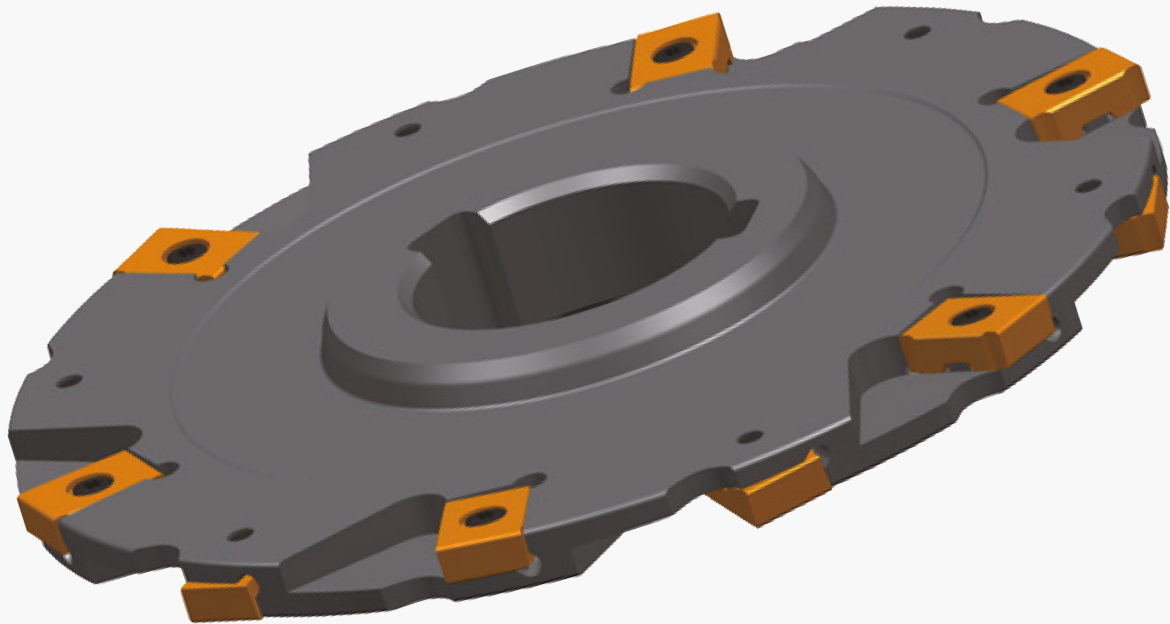

**BOR CARBIDE  
SLOT MILLING**

■ Insert Series --- LNHT

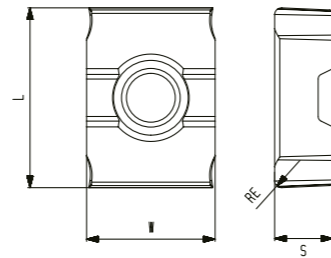
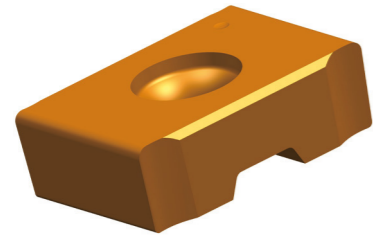

| Workpiece Material | P Steel | M Stainless steel | K Cast Iron | N Non-ferrous Metals | S High-Temperature Alloys | H High-Hardness Materials | stable cutting condition normal cutting condition bad cutting condition |   |   |    |     |   |     |  |  |  |            |  |
|--------------------|---------|-------------------|-------------|----------------------|---------------------------|---------------------------|---|---|---|----|-----|---|-----|--|--|--|------------|--|
|                    |         |                   |             |                      |                           |                           | Dimension   |   |   |    | CVD |   | PVD |  |  |  | No Coating |  |
|                    |         |                   |             |                      |                           |                           | L   | W | S | RE |     |   |     |  |  |  |            |  |
|                    | ●       | ●                 | ●           | ●                    | ●                         | ●                         | ●   | ● | ● | ●  | ●   | ○ | ●   |  |  |  |            |  |
|                    | ●       | ●                 | ●           | ●                    | ●                         | ●                         | ●   | ● | ● | ●  | ●   | ○ | ●   |  |  |  |            |  |
|                    | ●       | ●                 | ●           | ●                    | ●                         | ●                         | ●   | ● | ● | ●  | ●   | ○ | ●   |  |  |  |            |  |
|                    | ●       | ●                 | ●           | ●                    | ●                         | ●                         | ●   | ● | ● | ●  | ●   | ○ | ●   |  |  |  |            |  |
|                    | ●       | ●                 | ●           | ●                    | ●                         | ●                         | ●   | ● | ● | ●  | ●   | ○ | ●   |  |  |  |            |  |
|                    | ●       | ●                 | ●           | ●                    | ●                         | ●                         | ●   | ● | ● | ●  | ●   | ○ | ●   |  |  |  |            |  |

● Stock available ○ Make-to-order

■ Insert Series-----

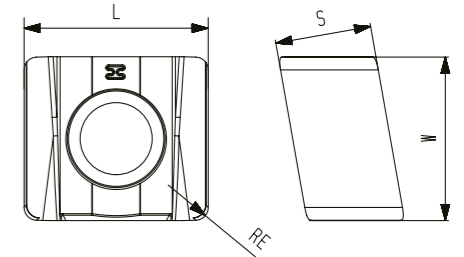
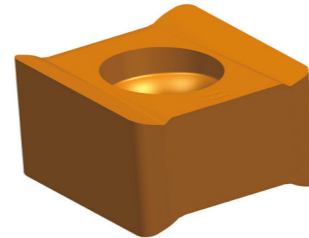

| Workpiece Material | P Steel | M Stainless steel | K Cast Iron | N Non-ferrous Metals | S High-Temperature Alloys | H High-Hardness Materials | stable cutting condition normal cutting condition bad cutting condition |   |   |    |     |   |     |  |  |  |            |  |
|--------------------|---------|-------------------|-------------|----------------------|---------------------------|---------------------------|---|---|---|----|-----|---|-----|--|--|--|------------|--|
|                    |         |                   |             |                      |                           |                           | Dimension   |   |   |    | CVD |   | PVD |  |  |  | No-coating |  |
|                    |         |                   |             |                      |                           |                           | L   | W | S | RE |     |   |     |  |  |  |            |  |
|                    | ●       | ●                 | ●           | ●                    | ●                         | ●                         | ●   | ● | ● | ●  | ●   | ● | ●   |  |  |  |            |  |
|                    | ●       | ●                 | ●           | ●                    | ●                         | ●                         | ●   | ● | ● | ●  | ●   | ● | ●   |  |  |  |            |  |
|                    | ○       | ●                 | ●           | ●                    | ●                         | ●                         | ●   | ● | ● | ●  | ●   | ○ | ●   |  |  |  |            |  |
|                    | ●       | ●                 | ●           | ●                    | ●                         | ●                         | ●   | ● | ● | ●  | ●   | ● | ●   |  |  |  |            |  |
|                    | ●       | ●                 | ●           | ●                    | ●                         | ●                         | ●   | ● | ● | ●  | ●   | ○ | ●   |  |  |  |            |  |
|                    | ●       | ●                 | ●           | ●                    | ●                         | ●                         | ●   | ● | ● | ●  | ●   | ● | ●   |  |  |  |            |  |
|                    | ○       | ●                 | ●           | ●                    | ●                         | ●                         | ●   | ● | ● | ●  | ●   | ○ | ●   |  |  |  |            |  |
|                    | ●       | ●                 | ●           | ●                    | ●                         | ●                         | ●   | ● | ● | ●  | ●   | ● | ●   |  |  |  |            |  |
|                    | ●       | ●                 | ●           | ●                    | ●                         | ●                         | ●   | ● | ● | ●  | ●   | ● | ●   |  |  |  |            |  |
|                    | ●       | ●                 | ●           | ●                    | ●                         | ●                         | ●   | ● | ● | ●  | ●   | ● | ●   |  |  |  |            |  |
|                    | ●       | ●                 | ●           | ●                    | ●                         | ●                         | ●   | ● | ● | ●  | ●   | ● | ●   |  |  |  |            |  |

● Stock available ○ Make-to-order

■ Tool Series---Disc Type

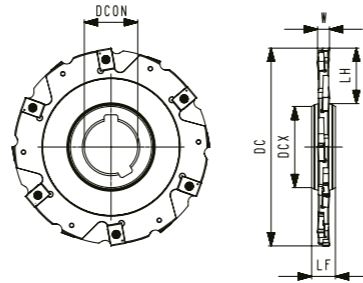
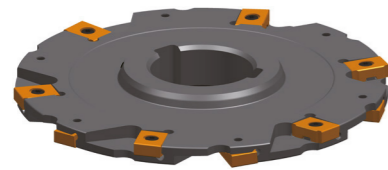

| Type                  | Stock | Number of flutes | Dimension |     |      |    |    |    | Interface | Adapt able Inserts | Screw    | Wrench |
|-----------------------|-------|------------------|-----------|-----|------|----|----|----|-----------|--------------------|----------|--------|
|                       |       |                  | DC        | DCX | DCON | LF | LH | W  |           |                    |          |        |
| SM01-X27-100-04-LN024 | ●     | 12               | 100       | 41  | 27   | 12 | 27 | 4  | X         | LNHT024-R04        | SA02503X | T08P   |
| SM01-X40-125-04-LN024 | ○     | 14               | 125       | 55  | 40   | 12 | 32 | 4  | X         |                    |          |        |
| SM01-X40-160-04-LN024 | ○     | 18               | 160       | 55  | 40   | 12 | 50 | 4  | X         |                    |          |        |
| SM01-X27-100-05-LN029 | ●     | 12               | 100       | 41  | 27   | 12 | 27 | 5  | X         | LNHT029-R04        | SA02504X | T08P   |
| SM01-X40-125-05-LN029 | ○     | 14               | 125       | 55  | 40   | 12 | 32 | 5  | X         |                    |          |        |
| SM01-X40-160-05-LN029 | ○     | 18               | 160       | 55  | 40   | 12 | 50 | 5  | X         |                    |          |        |
| SM01-X27-100-06-LN034 | ●     | 12               | 100       | 41  | 27   | 12 | 27 | 6  | X         | LNHT034-R04        | SA02505X | T08P   |
| SM01-X40-125-06-LN034 | ○     | 14               | 125       | 55  | 40   | 12 | 32 | 6  | X         |                    |          |        |
| SM01-X40-160-06-LN034 | ○     | 18               | 160       | 55  | 40   | 12 | 50 | 6  | X         |                    |          |        |
| SM01-X27-100-07-LN039 | ●     | 10               | 100       | 41  | 27   | 12 | 27 | 7  | X         | LNHT039-R04        | SA0406X  | T15P   |
| SM01-X40-125-07-LN039 | ○     | 12               | 125       | 55  | 40   | 12 | 32 | 7  | X         |                    |          |        |
| SM01-X40-160-07-LN039 | ○     | 16               | 160       | 55  | 40   | 12 | 50 | 7  | X         |                    |          |        |
| SM01-X27-100-08-LN044 | ●     | 10               | 100       | 41  | 27   | 12 | 27 | 8  | X         | LNHT044-R04        | SA0406X  | T15P   |
| SM01-X40-125-08-LN044 | ○     | 12               | 125       | 55  | 40   | 12 | 32 | 8  | X         |                    |          |        |
| SM01-X40-160-08-LN044 | ○     | 16               | 160       | 55  | 40   | 12 | 50 | 8  | X         |                    |          |        |
| SM01-X27-100-10-LN054 | ●     | 10               | 100       | 41  | 27   | 12 | 27 | 10 | X         | LNHT054-R04        | SA0407X  | T15P   |
| SM01-X40-125-10-LN054 | ●     | 12               | 125       | 55  | 40   | 12 | 32 | 10 | X         |                    |          |        |
| SM01-X40-160-10-LN054 | ●     | 16               | 160       | 55  | 40   | 12 | 50 | 10 | X         |                    |          |        |
| SM01-X27-100-11-LN059 | ●     | 10               | 100       | 41  | 27   | 13 | 27 | 11 | X         | LNHT054-R04        | SA0509   | T20P   |
| SM01-X40-125-11-LN059 | ●     | 12               | 125       | 55  | 40   | 13 | 32 | 11 | X         |                    |          |        |
| SM01-X40-160-11-LN059 | ●     | 16               | 160       | 55  | 40   | 13 | 50 | 11 | X         |                    |          |        |

● Stock available ○ Make-to-order

■ Tool Series ---

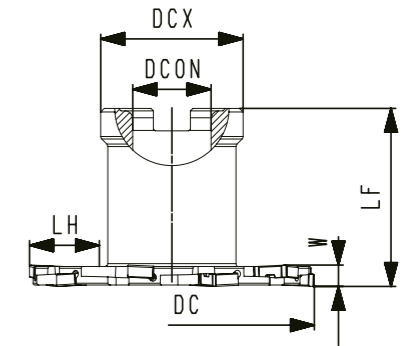

| Type                  | Stock | Number of flutes | Dimension |     |      |    |    |    | Interface | Adapt able Inserts | Screw    | Wrench |
|-----------------------|-------|------------------|-----------|-----|------|----|----|----|-----------|--------------------|----------|--------|
|                       |       |                  | DC        | DCX | DCON | LF | LH | W  |           |                    |          |        |
| SM01-A22-80-04-LN024  | ○     | 10               | 80        | 40  | 22   | 50 | 20 | 4  | A         | LNHT024-R04        | SA02503X | T08P   |
| SM01-A27-100-04-LN024 | ●     | 12               | 100       | 48  | 27   | 50 | 26 | 4  | A         |                    |          |        |
| SM01-A22-80-05-LN029  | ○     | 10               | 80        | 40  | 22   | 50 | 20 | 5  | A         | LNHT029-R04        | SA02504X | T08P   |
| SM01-A27-100-05-LN029 | ○     | 12               | 100       | 48  | 27   | 50 | 26 | 5  | A         |                    |          |        |
| SM01-A22-80-06-LN034  | ○     | 10               | 80        | 40  | 22   | 50 | 20 | 6  | A         | LNHT034-R04        | SA02505X | T08P   |
| SM01-A27-100-06-LN034 | ●     | 12               | 100       | 48  | 27   | 50 | 26 | 6  | A         |                    |          |        |
| SM01-B40-125-06-LN034 | ○     | 14               | 125       | 70  | 40   | 50 | 25 | 6  | B         |                    |          |        |
| SM01-B40-160-06-LN034 | ○     | 18               | 160       | 70  | 40   | 50 | 42 | 6  | B         | LNHT039-R04        | SA0406X  | T15P   |
| SM01-A22-80-07-LN039  | ○     | 8                | 80        | 40  | 22   | 50 | 20 | 7  | A         |                    |          |        |
| SM01-A27-100-07-LN039 | ●     | 10               | 100       | 48  | 27   | 50 | 26 | 7  | A         |                    |          |        |
| SM01-B40-125-07-LN039 | ○     | 12               | 125       | 70  | 40   | 50 | 25 | 7  | B         | LNHT044-R04        | SA0406X  | T15P   |
| SM01-B40-160-07-LN039 | ○     | 16               | 160       | 70  | 40   | 50 | 42 | 7  | B         |                    |          |        |
| SM01-A22-80-08-LN044  | ○     | 8                | 80        | 40  | 22   | 50 | 20 | 8  | A         | LNHT044-R04        | SA0406X  | T15P   |
| SM01-A27-100-08-LN044 | ●     | 10               | 100       | 48  | 27   | 50 | 26 | 8  | A         |                    |          |        |
| SM01-B40-125-08-LN044 | ○     | 12               | 125       | 70  | 40   | 50 | 25 | 8  | B         |                    |          |        |
| SM01-B40-160-08-LN044 | ○     | 16               | 160       | 70  | 40   | 50 | 42 | 8  | B         | LNHT054-R04        | SA0407X  | T15P   |
| SM01-A27-100-10-LN054 | ●     | 10               | 100       | 48  | 27   | 50 | 26 | 10 | A         |                    |          |        |
| SM01-B40-125-10-LN054 | ●     | 12               | 125       | 70  | 40   | 50 | 25 | 10 | B         |                    |          |        |
| SM01-B40-160-10-LN054 | ●     | 16               | 160       | 70  | 40   | 50 | 42 | 10 | B         | LNHT059-R04        | SA0509   | T20P   |
| SM01-A27-100-11-LN059 | ●     | 10               | 100       | 48  | 27   | 50 | 26 | 11 | A         |                    |          |        |
| SM01-B40-125-11-LN059 | ●     | 12               | 125       | 70  | 40   | 50 | 25 | 11 | B         | LNHT059-R04        | SA0509   | T20P   |
| SM01-B40-160-11-LN059 | ●     | 16               | 160       | 70  | 40   | 50 | 42 | 11 | B         |                    |          |        |

● Stock available ○ Make-to-order

■ Tool Series--- Disc Type

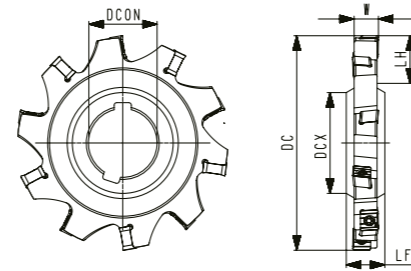
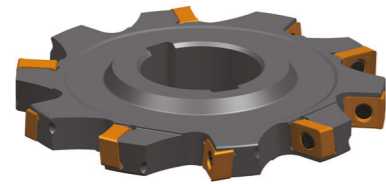

| Type                 | Stock | Number of flute | Dimension |     |      |    |          | Interface | Adapt able Inserts | Screw   | Wrench |
|----------------------|-------|-----------------|-----------|-----|------|----|----------|-----------|--------------------|---------|--------|
|                      |       |                 | DC        | DCX | DCON | LH | W        |           |                    |         |        |
| SM02-X32-100-10-LN08 | ●     | 10              | 100       | 47  | 32   | 24 | 10、12、14 | X         | LNHT08-R08         | SA03085 | T09P   |
| SM02-X40-125-10-LN08 | ●     | 12              | 125       | 55  | 40   | 33 | 10、12、14 | X         |                    |         |        |
| SM02-X40-160-10-LN08 | ●     | 14              | 160       | 55  | 40   | 50 | 10、12、14 | X         |                    |         |        |
| SM02-X32-100-16-LN10 | ●     | 10              | 100       | 47  | 32   | 24 | 16、18    | X         | LNHT10-R08         | SA04011 | T15P   |
| SM02-X40-125-16-LN10 | ●     | 12              | 125       | 55  | 40   | 33 | 16、18    | X         |                    |         |        |
| SM02-X40-160-16-LN10 | ●     | 14              | 160       | 55  | 40   | 50 | 16、18    | X         |                    |         |        |
| SM02-X32-100-20-LN12 | ●     | 10              | 125       | 47  | 32   | 24 | 20、22    | X         | LNHT12-R08         | SA04011 | T15P   |
| SM02-X40-125-20-LN12 | ●     | 12              | 160       | 55  | 40   | 33 | 20、22    | X         |                    |         |        |
| SM02-X40-160-20-LN12 | ●     | 14              | 200       | 69  | 40   | 50 | 20、22    | X         |                    |         |        |

● Stock available ○ Make-to-order

■ Tool Series---Shank Amount Type

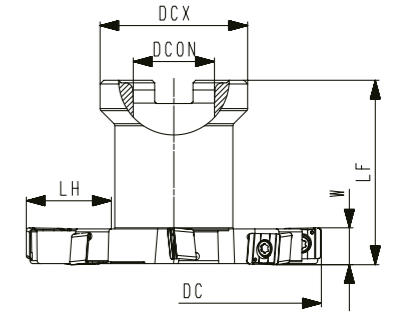
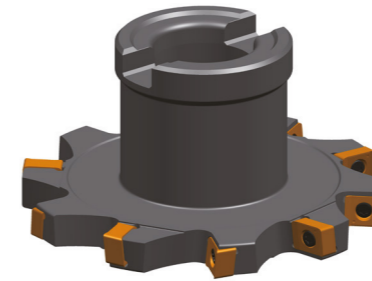

| Type                 | Stock | Number of flutes | Dimension |     |      |    |    |          | Interface | Adapt able Inserts | Screw   | Wrench |
|----------------------|-------|------------------|-----------|-----|------|----|----|----------|-----------|--------------------|---------|--------|
|                      |       |                  | DC        | DCX | DCON | LF | LH | W        |           |                    |         |        |
| SM02-A22-80-10-LN08  | ●     | 8                | 80        | 40  | 22   | 50 | 24 | 10、12、14 | A         | LNHT08-R08         | SA03085 | T09P   |
| SM02-A27-100-10-LN08 | ●     | 10               | 100       | 48  | 27   | 50 | 27 | 10、12、14 | A         |                    |         |        |
| SM02-B32-125-10-LN08 | ●     | 12               | 125       | 58  | 32   | 50 | 34 | 10、12、14 | B         |                    |         |        |
| SM02-B40-160-10-LN08 | ●     | 14               | 160       | 70  | 40   | 50 | 46 | 10、12、14 | B         | LNHT10-R08         | SA04011 | T15P   |
| SM02-A22-80-16-LN10  | ●     | 8                | 80        | 40  | 22   | 50 | 24 | 16、18    | A         |                    |         |        |
| SM02-A27-100-16-LN10 | ●     | 10               | 100       | 48  | 27   | 50 | 27 | 16、18    | A         |                    |         |        |
| SM02-B32-125-16-LN10 | ●     | 12               | 125       | 58  | 32   | 50 | 34 | 16、18    | B         | LNHT12-R08         | SA04011 | T15P   |
| SM02-B40-160-16-LN10 | ●     | 14               | 160       | 70  | 40   | 50 | 46 | 16、18    | B         |                    |         |        |
| SM02-A22-80-20-LN12  | ●     | 8                | 80        | 40  | 22   | 50 | 24 | 20、22    | A         |                    |         |        |
| SM02-A27-100-20-LN12 | ●     | 10               | 100       | 48  | 27   | 50 | 27 | 20、22    | A         | LNHT12-R08         | SA04011 | T15P   |
| SM02-B32-125-20-LN12 | ●     | 12               | 125       | 58  | 32   | 50 | 34 | 20、22    | B         |                    |         |        |
| SM02-B40-160-20-LN12 | ●     | 14               | 160       | 70  | 40   | 50 | 46 | 20、22    | B         |                    |         |        |

● Stock available ○ Make-to-order

# BOR

## CARBIDE



Yakuplu Mah. Hürriyet Bulvarı Skyport Residence  
No: 1 Kat: 3 No: 64-65 Beylikdüzü / İstanbul



0850 309 14 72



0850 522 34 03



[www.borcarbide.com](http://www.borcarbide.com)